

Datasheet

Features

- High Sensitivity and high Performance Linear CCD
- 8192 Resolution with 7 μm Square Pixels
- 100% Aperture, Built-in Anti-blooming, No Lag
- Camera Link[®] Data Format (Medium Configuration)
- Up to 18.8 kHz Line Rate
- High Data Rate: Up to 160 Mpixels/s
- Flexible and Easy to Operate via Serial Control Lines:
 - Gain: Up to 40 dB by Step of 0.035 dB
 - Output Mode: 8, 10, 12-bit Data on 2 or 4 Taps
 - Offset (for Contrast Expansion)
 - Trigger Mode: Free-run or External Trigger Modes
- Flat-field Correction (Lens and Light Non-uniformity Correction)
- Automatic Taps Balancing
- Single Power Supply: DC 12 to 24V
- Very Compact Design: 76 × 76 × 56 mm (w, h, l)
- High reliability, RoHS, CE and FCC Compliant
- M72 × 0.75 Mount Adapter



Description

The AViVA Line Scan family associates technical performances and simplicity of use. e2v manages the entire manufacturing process, from the sensor to the camera. The design of the AViVA UM4 provides simplicity of use and high performances within a compact housing. It includes fine automatic-balancing taps, flat field correction and a high gain setting range.

Application

High speed, high resolution, performance and reliability of this camera make it well suited for the most demanding industrial applications (web inspection, document scanning, surface inspection). It is especially well dedicated for Flat Panel Display and Printed Circuit Board inspection (PCB) or high speed document scanning.

Visit our website: www.e2v.com
for the latest version of the datasheet

1. Typical Performances

Test conditions:

- Maximum data rate (4 × 40 MHz)
- Light source 3200K with BG38 filter 2 mm thickness
- LSB are given for 12-bit depth configuration

Table 1-1. Typical Performances

| Parameter | Value | | | | Unit |
|--|----------------------------|-------|-------|------|------------------------|
| Sensor Characteristics | | | | | |
| Resolution | 8192 | | | | pixels |
| Pixel size | 7 x 7 | | | | µm |
| Line length | 57.3 | | | | mm |
| Maximum line rate | 18.8 | | | | kHz |
| Anti-blooming | × 100 | | | | |
| Radiometric Performances (Maximum Pixel Rate, T _{amb} = 25°C) | | | | | |
| Bit depth | 8, 10 or 12 | | | | Bit |
| Spectral range | 250 to 1100 | | | | nm |
| Nonlinearity | ±1 | | | | % |
| Gain | -12 dB | -9 dB | 0 dB | 9 dB | |
| Dynamic range | 1190:1 | 696:1 | 205:1 | 73:1 | |
| Integrated response | 43 | 60 | 171 | 482 | LSB/nj/cm ² |
| PRNU p-p (at FSR/2) | 0.7 | 1 | 4 | 15 | % |
| FPN p-p | <10 | <20 | <65 | <186 | LSB |
| FTM at Nyquist | 40 | | | | % |
| Mechanical and Electrical Interface | | | | | |
| Size (w × h × l) | 76 × 76 × 56 | | | | mm |
| Lens mount | M72 × 0.75 | | | | - |
| Sensor alignment (x, y and z axes) | ±0.05 | | | | mm |
| Power supply | DC, single 12 to 24 | | | | V |
| Power dissipation | 10 | | | | W |
| Weight | 430 | | | | g |
| Operating temperature | 0 to 55 (non-condensing) | | | | °C |
| Storage temperature | -40 to 70 (non-condensing) | | | | °C |

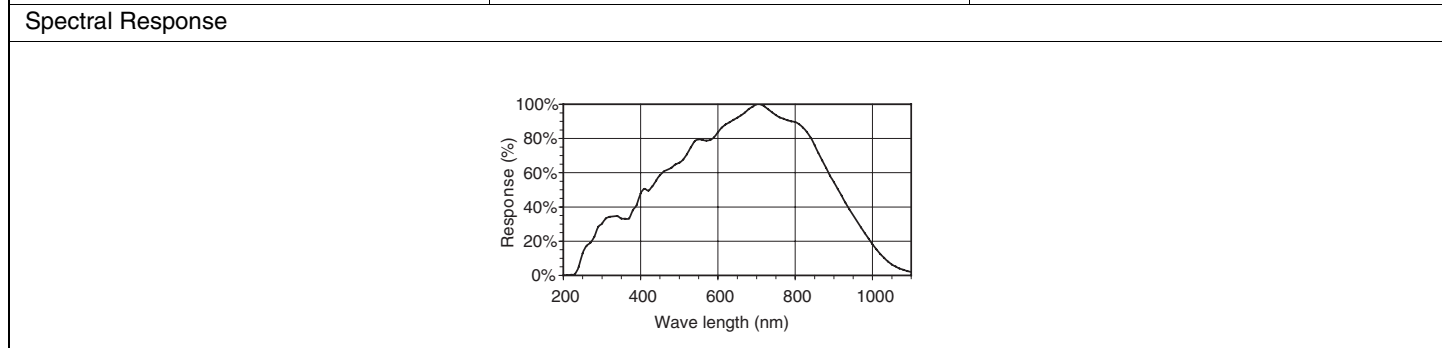

2. Camera Description

Figure 2-1. Sensor Block Diagram

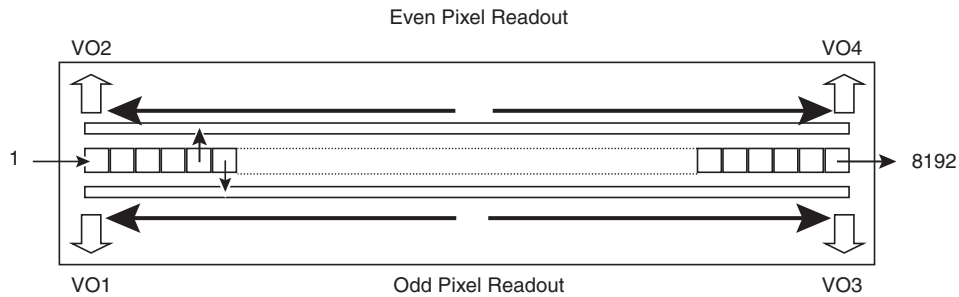
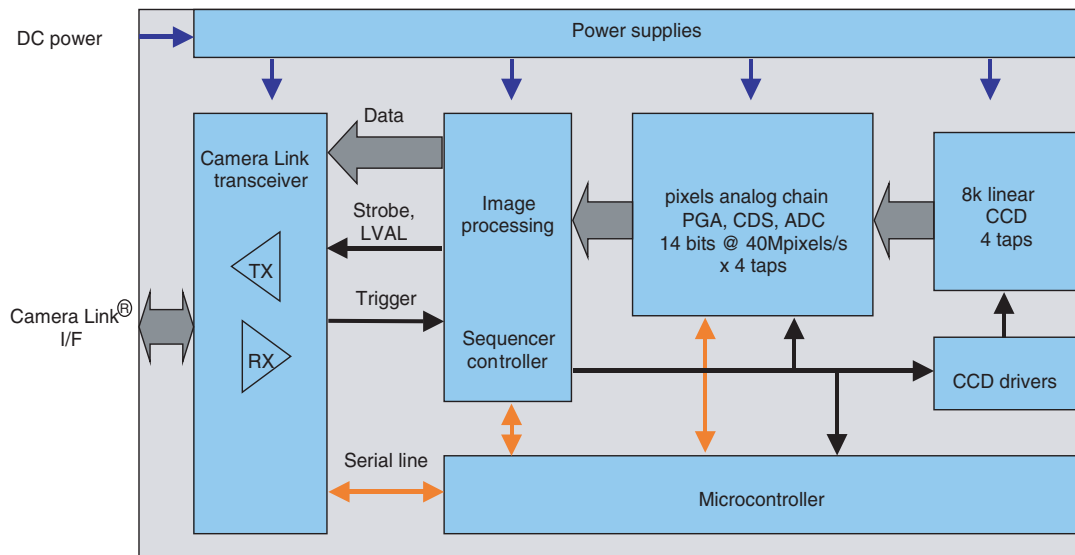

Figure 2-2. Camera Block Diagram



The camera is based on an four-taps linear CCD sensor. Therefore, four analog chains process pixels output of the linear sensor. The “CCD signal processor” encompasses the correlated double sampling (CDS), the dark level correction (dark pixel clamping) and the analog-to-digital conversion in 14-bit. Digital data are then processed into an FPGA (flat field correction, contrast expansion, automatic taps balancing and test pattern generation).

Data are output simultaneously on four channels (at 4 x 40 MHz) as follow:

Tap #1: pixel 1, 3, 5, ..., 4095

Tap #2 : pixel 2, 4, 6, ..., 4096

Tap #3: pixel 8191, 8189, 8187, ..., 4097

Tap #4 : pixel 8192, 8190, 8188, ..., 4098

In case of *two output channels* mode, Taps are multiplexed two by two (Tap#1 with Tap#2, Tap#3 with Tap#4). The data frequency is 2 x 80 MHz.

The functional interface (data and control) is provided by the Camera Link interface. The camera uses the *medium* configuration of Camera Link standard with DVAL = 1 and FVAL = 1.

3. Standard Conformity

The AViiVA cameras have been tested using the following equipment:

- A shielded power supply cable
- A Camera Link data transfer cable ref. 14B26-SZLB-500-OLC (3M)
- A linear AC-DC power supply

e2v recommends using the same configuration to ensure the compliance with the following standards.

3.1 CE Conformity

The AViiVA cameras comply with the requirements of the EMC (European) directive 89/336/CEE (EN 50081-2, EN 61000-6-2).

3.2 FCC Conformity

The AViiVA cameras further comply with Part 15 of the FCC rules, which states that:

Operation is subject to the following two conditions:

- This device may not cause harmful interference, and
- This device must accept any interference received, including interference that may cause undesired operation

This equipment has been tested and found to comply with the limits for Class A digital device, pursuant to part 15 of the FCC rules. These limits are designed to provide reasonable protection against harmful interference when the equipment is operated in a commercial environment. This equipment generates, uses and can radiate radio frequency energy and, if not installed and used in accordance with the instruction manual, may cause harmful interference to radio communications. Operation of this equipment in a residential area is likely to cause harmful interference in which case the user will be required to correct the interference at his own expense.

Warning: Changes or modifications to this unit not expressly approved by the party responsible for compliance could void the user's authority to operate this equipment.

4. Camera Command and Control

The camera configuration is set through the serial interface. After adjustments, all the parameters may be stored in an embedded E2Prom memory.

4.1 Syntax

Internal camera configurations are activated by write or readout commands.

The command syntax for write operation is:

```
w <command_name> <command_parameters><CR>
```

The command syntax for readout operation is:

```
r <command_name><CR>
```

4.2 Command Processing

Each command received by the camera is processed:

1. The setting is implemented (if valid)
2. The camera returns ">"<return code><CR>

We recommend waiting for the camera return code before sending a new command.

Table 4-1. Camera Returned Code

| Return Code | Meaning |
|-------------|---|
| >0 | (or >"OK": All right, the command will be implemented) |
| >3 | Error bad CRC in command |
| >16 | Command error (Command not recognized or do not exist) |
| >21 | Invalid command ID (the Command do not exist) |
| >33 | Invalid access (the receipt of the last command has failed) |
| >34 | Parameter out-of-range (the parameter of the last command send is out-of-range) |
| >35 | Access failure (bad communication between two internal devices) |

4.3 List of Commands

Table 4-2. Usual Features

| Title | Command | Features |
|---------------|--------------|--|
| Output mode | w mode 0 | Set 4 output channels, 8-bit, medium configuration |
| | w mode 1 | Set 4 output channels, 10-bit, medium configuration |
| | w mode 2 | Set 4 output channels, 12-bit, medium configuration |
| | w mode 3 | Set 2 output channels, 8-bit, base configuration |
| | w mode 4 | Set 2 output channels, 10-bit, base configuration |
| | w mode 5 | Set 2 output channels, 12-bit, base configuration |
| | r mode | Get current output mode |
| Exposure time | w tint <val> | Set exposure time to <val>, from 1 to 65535 0.1 μ s to 6553 μ s by 0.1 μ s step |
| | r tint | Get current exposure time |
| Line period | w tper <val> | Set line period to <val> from 532 to 65535 0.1 μ s to 6553 μ s by 0.1 μ s step |
| | r tper | Get current line period |
| Pre-amp gain | w pamp <val> | Set pre-amp gain to: 0 (-3.9 dB), 1 (-2.6 dB), 2 (-1.3 dB), 3 (0 dB) |
| | r pamp | Get current pre-amp gain |

Table 4-2. Usual Features (Continued)

| Title | Command | Features |
|---------------------------------|--------------|--|
| Gain | w gain <val> | Set gain from -237 (-8.32 dB) to +416 (14.6 dB) by step of 0.0351 dB |
| | r gain | Get current gain |
| Digital gain | w.gdig<val> | Set digital gain from 0 to 255 |
| | r gdig | DG (dB) = 20 log (1+val/64) |
| Offset | w offs <val> | Set global offset from -4096 to +4095 in 12 bits LSB |
| | r offs | Get global offset |
| Synchronization mode | w sync 0 | Set "Free run" mode |
| | w sync 1 | Set "Triggered mode with exposure time setting" |
| | w sync 2 | Set "Triggered mode with maximum exposure time" |
| | w sync 3 | Set "Triggered mode with exposure time controlled by one signal" |
| | w sync 4 | Set "Triggered mode with exposure time controlled by two signals" |
| | r sync | Get current Synchronization mode |
| Signal source | w srce 0 | Set signal source to CCD sensor |
| | w srce 1 | Set signal source to pattern |
| | r srce | Get current signal source |
| Flat field correction | w ffc 0 | Disable Flat Field Correction |
| | w ffc 1 | Enable Flat Field Correction |
| | r ffc | Get current FFC status |
| Flat field calibration (Offset) | w calo 1 | Start Flat Field calibration; OnePush button (auto disable once finished) |
| | w calo 0 | Abort Flat Field calibration |
| | r calo | Get the Flat Field calibration status: 1 if running, 0 when finished |
| Flat field calibration (Gain) | w calg 1 | Start Flat Field calibration; OnePush button (auto disable once finished) |
| | W calg 0 | Abort Flat Field calibration |
| | r calg | Get the Flat Field calibration status: 1 if running, 0 when finished |
| Flat field reset (Offset) | w rsto 0 | Clear Offset Flat Field Coefficients to 0 |
| Flat field reset (Gain) | w rstg 0 | Set Gain Flat Field coefficients to 1 |
| FFC bank | w sffc <val> | Save current FFC into FFC bank number <val> (1 to 4) |
| | w rffc <val> | Load current FFC from FFC bank number <val> (1 to 4) |
| | r rffc | Get the current FFC bank used (saved or loaded) |
| Taps balance ⁽¹⁾ | w balg 1 | Start <i>Taps balance</i> ; OnePush button (auto disable once finished) |
| | w balg 0 | Abort <i>Tap balance</i> |
| | r balg | Get the <i>Tap balance</i> status: 1 if running, 0 when finished |
| Taps balance bank | w sbal <val> | Save current <i>Tap Balance</i> into bank number <val> (0 to 4) |
| | w rbal <val> | Load current <i>Tap Balance</i> from bank number <val> (1 to 4) Bank 0 = factory settings |
| | r bal | Get the current <i>Tap Balance</i> bank used (saved or loaded) |

Table 4-2. Usual Features (Continued)

| Title | Command | Features |
|------------------|----------------|--|
| ModelName | r mdnm | Get camera model name |
| Camera ID | r idnb | Get camera ID |
| Customer ID | w cust <idstr> | Set customer ID to <idstr> (max 50 bytes) |
| | r cust | Get customer ID Return <idstr> |
| Software version | r vers | Get the camera software version |
| Dump | r dump | Get full camera configuration with the format: idnb EV71... fing 5 fga1 120 |
| Configuration | w scfg <val> | Save current configuration into bank number <val> (1 to 4) |
| | w rcfg 0 | Load current configuration from factory bank (0) |
| | w rcfg <val> | Load current configuration from bank number <val> (1 to 4) |
| | w rcfg 5 | Load current configuration from integrator bank (5). |
| | r rcfg | Get the current configuration bank used (saved or loaded) |

Note: 1. Usable only in synchronization mode **0** (free run) and **1** (triggered with exposure time setting).

Table 4-3. Advanced features

| Title | Command | Features |
|----------------------------------|---|--|
| Gain Adjustment | w fga<i> <val> | Set gain adjustment for Tap#<i> (1 to 4), from -128 (-0.26 dB) to 127 (0.26 dB), step 0.0021 dB |
| | r fga<i> | Get gain adjustment for Tap#<i> (1 to 4) |
| Clamp Adjustment | w off<i> <val> | Set clamp adjustment for Tap#<i> (1 to 4), from -128 to 127 (12-bit LSB) |
| | r off<i> | Get clamp adjustment for Tap#<i> (1 to 4) |
| Flat Field Coefficients (Offset) | w ffco <addr> <nbrval> <val> ...[crcval] | Write <nbrval> coefficients starting from the <addr> address.If [crcval] is added, the crc value is computed on the all the<val>.<addr> starts from 1. <val> is signed. <nbrval> is between 1 and 10 |
| | r ffco <addr> <nbrval> [crcreq] | Read <nbrval> coefficients starting from <addr> address.If [crcreq] is equal to 1, the crc will be calculated on the <val>. <nbrval> is between 1 and 10. Output is : <val> ...[crcval] |
| Flat Field coefficients (Gain) | w ffcg <addr> <nbrval> <val> ... [crcval] | Write <nbrval> coefficients starting from the <addr> address. If [crcval] is added, the crc value is computed on the all the <val>.<addr> starts from 1 |
| | r ffcg <addr> <nbrval> [crcreq] | Read <nbrval> coefficients starting from <addr> address. If [crcreq] is equal to 1, the crc will be calculate on the outputed value. Output is : <val> ...[crcval] |
| VendorName | r vdnm | Get camera vendor name |
| Status | r stat | Get camera status |
| Baudrate | w baud 1 | Set CL RS232 baudrate to 9600 Bds (default value) |
| | w baud 2 | Set CL RS232 baudrate to 19200 Bds |
| | w baud 6 | Set CL RS232 baudrate to 57600 Bds |
| | w baud 12 | Set CL RS232 baudrate to 115200 Bds |
| | w baud 24 | Set CL RS232 baudrate to 230400 Bds (for compatible frame grabber) |
| | r baud | Get current baudrate |

5. Camera Status

The camera status can be read by **r stat** command (see [Table 5-1](#)).

The camera return is a 32-bit value.

Table 5-1. Camera Status

| Bit | Status Name | Description |
|----------|---------------------------|--|
| 31 .. 22 | not used | Set to 0 |
| 21 .. 16 | internal error | |
| 15 .. 12 | not used | Set to 0 |
| 11 | FFC/Taps balance status | 1: in progress 0: disabled or finished |
| 10 | FFC/Tap balance underflow | Updated after each calibration operation. 1: output level is too high during calibration 0: calibration is well done |
| 9 | FFC/Tap balance overflow | Updated after each calibration operation. 1: output level is too low during calibration 0: calibration is well done |
| 8 | not used | Set to 0 |
| 7 | settings change | 1: states that at least one parameter has been modified and might be saved. Set to 0 during save or restore operation |
| 6 | Tap Balance change | |
| 5 | FFC change | |
| 4 .. 2 | not used | Set to 0 |
| 1 | Trigger too fast | set to 1 if trigger too fast, else 0. |
| 0 | Waiting for trigger | Set to 1 if no trigger in "external trigger" mode. |

6. Flat Field Correction

The flat field correction consist in applying Ax formula to each pixel value. This allows to correct:

- The lens vignetting
- The light source non-uniformity

6.1 Offset Calibration

Calibration procedure:

1. Set the camera in the useful configuration.
2. Switch off the light (or mask the lens).
3. Start the flat field (offset) calibration.

6.2 Gain Calibration

Calibration procedure:

1. Set the camera in the useful configuration.
2. Switch on the light and place a white reference in front of the camera. Be careful, the quality of this reference is important to get a good calibration.
3. Set parameters (light level, exposure time, gain) to get an output level just above saturation.
4. Start Flat Field calibration (gain).
5. If the result is correct save it in FFC user bank.

7. Tabs Balance

Due to response difference between each sensor tap, the user must balance the taps. There are two methods to implement this:

- Manual balance using gain and offset adjustment (see [Section 4-3 on page 8](#))
- Automatic balance (“w balg1” command). Only usable in “free run” and “triggered with exposure time setting” modes, it gives the best result for a given configuration.

Beware that camera configuration change (global gain, offsets, etc.) might require a new balance.

Calibration procedure:

1. Set the camera in the useful configuration (gain, mode etc.).
2. Switch on the light and place a white reference in front of the camera.
3. Set parameters (light level, exposure time) to get an output level near saturation.
4. Start calibration.

8. Timing

8.1 Synchronization Mode

Five different modes may be defined by the user. The TRIG1 and TRIG2 signals may be used to trigger external events and control the exposure time.

Table 8-1. Timing Specifications (Typical Values)

| Label | Description | Typ |
|--------|--|--------------|
| td | Trigger to start of exposure delay | 0.28 μ s |
| th | External trigger hold time (minimum pulse high duration) | 0.16 μ s |
| it min | Minimum exposure time duration | 1.5 μ s |
| Lp | Line period | 53.2 μ s |
| te | End of exposure trigger to real end of exposure time delay | 1.42 μ s |
| ts | End of exposure time to start of exposure time delay | 1.7 μ s |
| rd | End of exposure period to readout delay | 0.8 μ s |
| rp | Readout duration | 51.2 μ s |
| tt | End of readout cycle to end of exposure time | 0.45 μ s |

8.2 Free Run Mode (With Exposure Time and Line Period Setting)

Syntax: `w sync 0`

The new line starts automatically and immediately after the previous one. If the programmed line period (`per`) is lower than the `Lp min` then the line period is set to the minimum line period. If the programmed exposure time (`int`) is greater than the programmed line period (`per`) then the line period is set to exposure time. The read-out time depends on the pixel number and the pixel rate.

Figure 8-1. Free-run Mode Timing Diagram

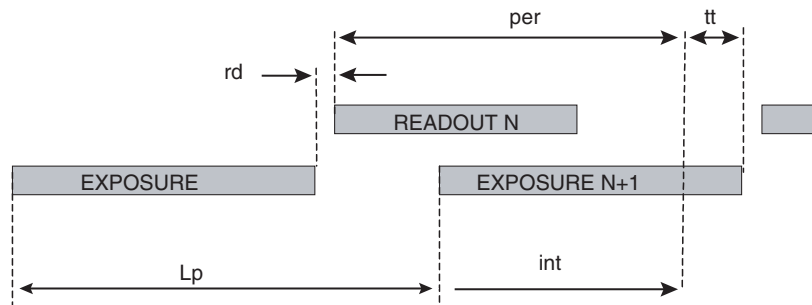

8.3 Triggered Mode with Exposure Time Setting

Syntax: `w sync 1`

The exposure period starts immediately after the rising edge of the TRIG1 input signal. The exposure time is set through the serial line. This exposure period is immediately followed by a readout period. The readout time depends on the number of pixels and the pixel rate.

Figure 8-2. Triggered Mode Timing Diagram

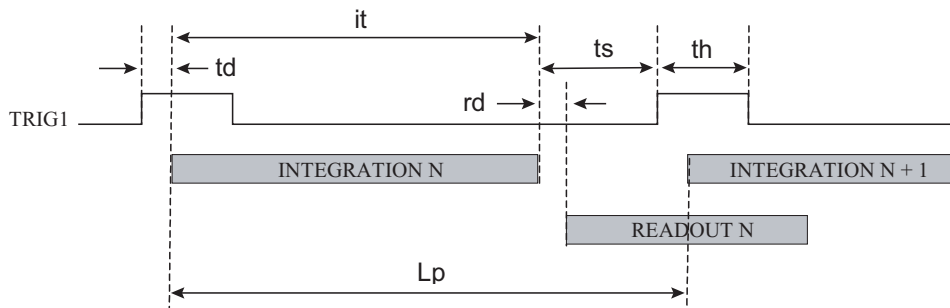

8.4 Triggered Mode with Maximum Exposure Time

Syntax: `w sync 2`

The readout period and the next exposure period start immediately after the rising edge of the TRIG1 input signal.

Figure 8-3. Triggered Readout Mode Timing Diagram

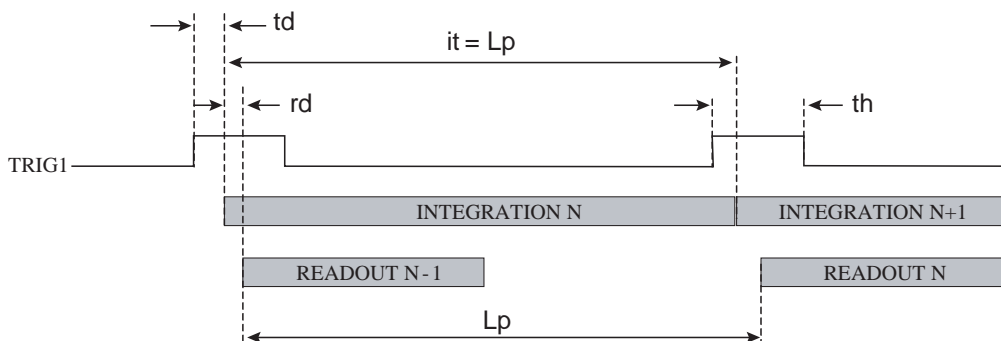

8.5 Triggered Mode with Exposure Time Controlled by One Signal

Syntax: `w sync 3`

The exposure period starts immediately after the falling edge of TRIG1 and stops immediately after the rising edge of TRIG1. This exposure period is immediately followed by a readout period. The readout time depends on the number of pixels and the pixel rate. The pixels are reset while TRIG1 is high.

Figure 8-4. ITC Mode with One Signal Timing Diagram

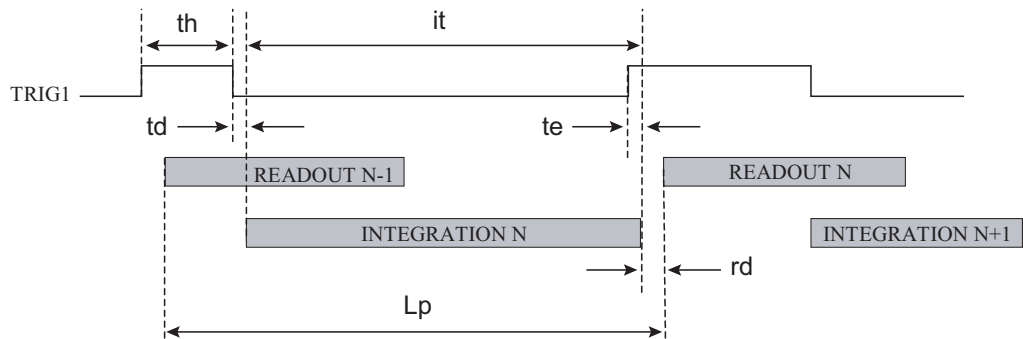

8.6 Triggered Mode with Exposure Time Controlled by Two Signals

Syntax: `w sync 4`

The rising edge of TRIG2 starts the exposure period. The rising edge of TRIG1 stops the exposure period and starts the readout period. The pixels are reset between the rising edge of TRIG1 and the rising edge of TRIG2.

Figure 8-5. ITC Mode with Two Signals Timing Diagram

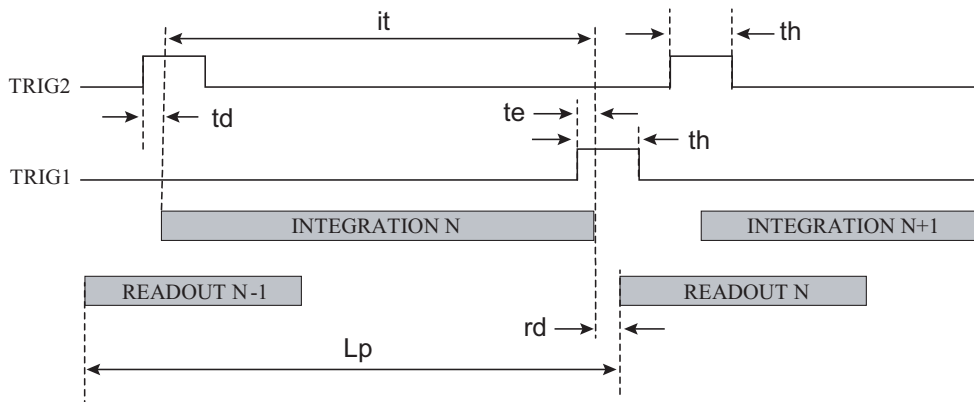

9. Output Data Timing

| Label | Description | Min | Typ | Max |
|-------|--------------------------------------|-------|-----|-------|
| td | STROBE to synchronized signals delay | -3 ns | | +3 ns |

Figure 9-1. Timing Diagram

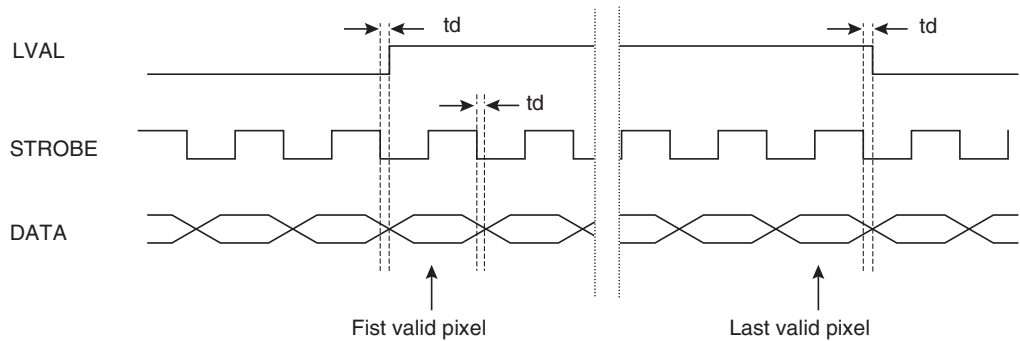

10. Electrical Interface

10.1 Power Supply

It is recommended to insert a two exposure A fuse between the power supply and the camera.

The power supply must provide 25W at power-on sequence.

| Signal name | I/O | Type | Description |
|-------------|-----|------|---|
| PWR | P | | DC power input: +12V to +24V ($\pm 0.5V$) |
| GND | P | | Electrical and Mechanical ground |

Note: I = input, O = output, I/O = bidirectional signal, P = power/ground, NC = not connected

10.2 Camera Control

The Camera Link interface provides four LVDS signals dedicated to camera control (CC1 to CC4). On the camera, two of them are used to synchronize the camera on external events.

| Signal name | I/O | Type | Description |
|-------------|-----|-------|--|
| TRIG1 | I | RS664 | CC1 - Synchronization input (refer to “Output Data Timing” on page 14) |
| TRIG2 | I | RS664 | CC2 - Start exposure period in dual synchronization mode |

Note: I = input, O = output, I/O = bidirectional signal, P = power/ground, NC = not connected

10.3 Video Data

Data and Enable signals are provided on the Camera Link interface

| Signal name | I/O | Type | Description |
|--------------------|-----|-------|---|
| OUT1-00 to OUT1-11 | O | RS644 | Tap#1 Output pixel data (OUT1-00 = LSB, OUT1-11 = MSB) |
| OUT2-00 to OUT2-11 | O | RS644 | Tap#2 Output pixel data (OUT2-00 = LSB, OUT2-11 = MSB) |
| OUT3-00 to OUT3-11 | O | RS644 | Tap#3 Output pixel data (OUT3-00 = LSB, OUT3-11 = MSB) |
| OUT4-00 to OUT4-11 | O | RS644 | Tap#4 Output pixel data (OUT4-00 = LSB, OUT4-11 = MSB) |
| STROBE | O | RS664 | Output data clock see “Output Data Timing” on page 14 , data valid on the rising edge |
| LVAL | O | RS664 | Line valid see “Output Data Timing” on page 14 , active high signal |

Note: I = input, O = output, I/O = bidirectional signal, P = power/ground, NC = not connected

FVAL, as defined in the Camera Link standard, is not used. FVAL is permanently tied to 0 (low) level.

DVAL is not used. DVAL is permanently tied to one (high) level.

10.4 Serial Communication

The Camera Link interface provides two LVDS signal pairs for communication between the camera and the frame grabber. This is an asynchronous serial communication based on RS-232 protocol.

The serial line configuration is:

- Full duplex/without handshaking
- 9600 bauds (default), 8-bit data, no parity bit, 1 stop bit. The baud rate can be set up to 230,400

| Signal name | I/O | Type | Description |
|-------------|-----|-------|---|
| SerTFG | O | RS644 | Differential pair for serial communication to the frame grabber |
| SerTC | I | RS644 | Differential pair for serial communication from the frame grabber |

11. Connector Description

All connectors are on the rear panel.

Note: Cables for digital signals must be shielded twisted pairs.

11.1 Power Supply

- Camera connector type:Hirose HR10A-7R-6PB (male)
- Cable connector type:Hirose HR10A-7P-6S (female)

Table 11-1. Power Supply Connector Pinout

| Signal | Pin | Signal | Pin |
|--------|-----|--------|-----|
| PWR | 1 | GND | 4 |
| PWR | 2 | GND | 5 |
| PWR | 3 | GND | 6 |

Figure 11-1. Receptacle Viewed from the Rear Face of the Camera

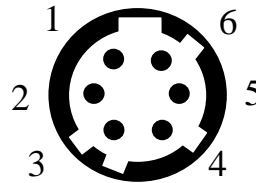

11.2 Camera Link Connector

A standard Camera Link cable must be used to ensure full electrical compatibility.

- The camera connector type is MDR-26 (female) ref. 10226-2210VE from 3M
- The cable connector type is a standard Camera Link cable

Table 11-2. Camera Link Connector Pinout

| Signal | Pin | Signal | Pin |
|---------|-----|---------|-----|
| GND | 1 | GND | 14 |
| X0- | 2 | X0+ | 15 |
| X1- | 3 | X1+ | 16 |
| X2- | 4 | X2+ | 17 |
| Xclk- | 5 | Xclk+ | 18 |
| X3- | 6 | X3+ | 19 |
| SerTC+ | 7 | SerTC- | 20 |
| SerTFG- | 8 | SerTFG+ | 21 |
| CC1- | 9 | CC1+ | 22 |
| CC2+ | 10 | CC2- | 23 |
| CC3- | 11 | CC3+ | 24 |
| CC4+ | 12 | CC4- | 25 |
| GND | 13 | GND | 26 |

12. Mechanical Dimensions

Figure 12-1. Mechanical Drawing

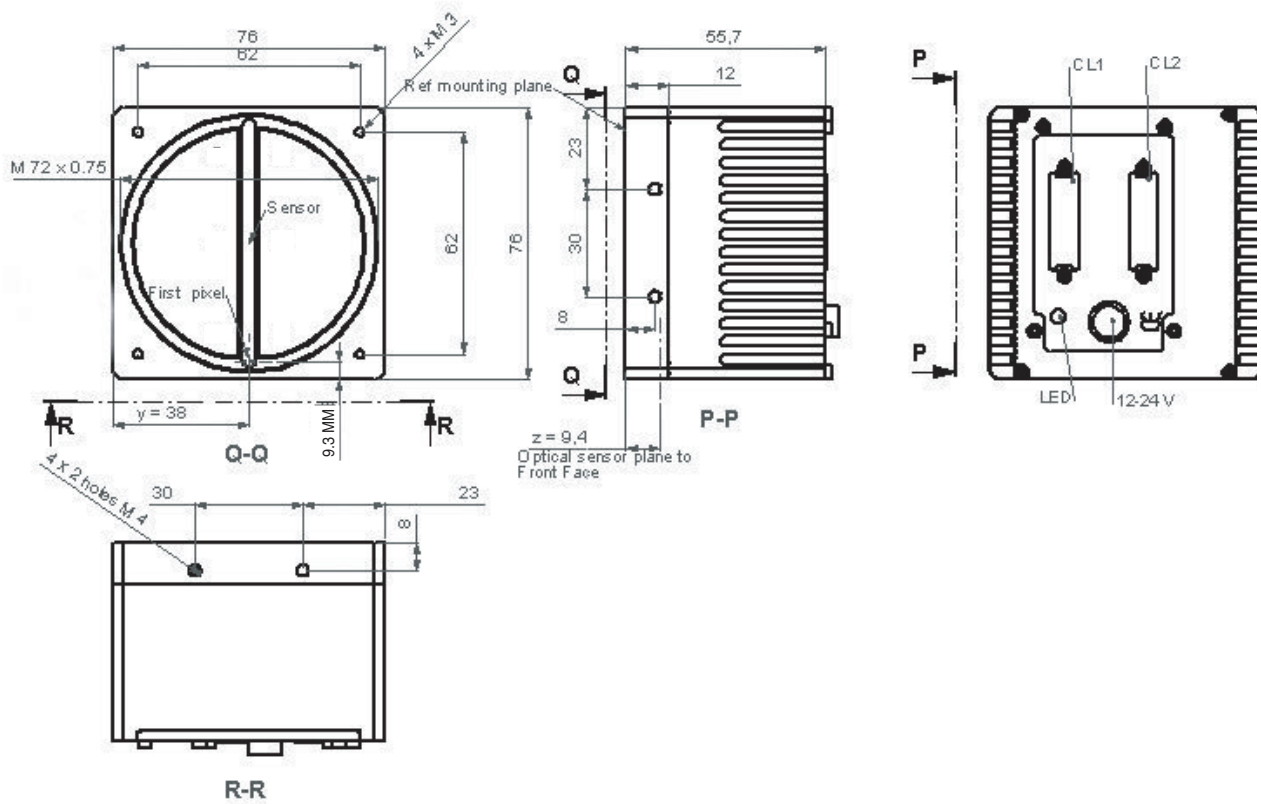

13. Ordering Code

Table 13-1. Ordering Code

| Part Number | Description |
|--------------------|--|
| EV71YUM4CL8007-BA0 | Camera, power supply connector and CD-ROM including configuration software and documentation |

Note: Lens is not provided



How to reach us

Home page: www.e2v.com

Sales offices:

Europe Regional sales office

e2v ltd

106 Waterhouse Lane
Chelmsford Essex CM1 2QU
England
Tel: +44 (0)1245 493493
Fax: +44 (0)1245 492492
mailto: enquiries@e2v.com

e2v sas

16 Burospace
F-91572 Bièvres Cedex
France
Tel: +33 (0) 16019 5500
Fax: +33 (0) 16019 5529
mailto: enquiries-fr@e2v.com

e2v gmbh

Industriestraße 29
82194 Gröbenzell
Germany
Tel: +49 (0) 8142 41057-0
Fax: +49 (0) 8142 284547
mailto: enquiries-de@e2v.com

Americas

e2v inc

520 White Plains Road
Suite 450 Tarrytown, NY 10591
USA
Tel: +1 (914) 592 6050 or 1-800-342-5338,
Fax: +1 (914) 592-5148
mailto: enquiries-na@e2v.com

Asia Pacific

e2v ltd

11/F.,
Onfem Tower,
29 Wyndham Street,
Central, Hong Kong
Tel: +852 3679 364 8/9
Fax: +852 3583 1084
mailto: enquiries-ap@e2v.com

Product Contact:

e2v
Avenue de Rochepleine
BP 123 - 38521 Saint-Egrève Cedex
France
Tel: +33 (0)4 76 58 30 00
Hotline:
mailto: hotline-cam@e2v.com



Whilst e2v has taken care to ensure the accuracy of the information contained herein it accepts no responsibility for the consequences of any use thereof and also reserves the right to change the specification of goods without notice. e2v accepts no liability beyond that set out in its standard conditions of sale in respect of infringement of third party patents arising from the use of tubes or other devices in accordance with information contained herein